

Exterior tram advertising – Tram 2000 / smooth-runner trams

Always on track

General information

For operational reasons, it is not possible to choose specific tram routes. The client shall assume the costs of design, production and transport of the advertising panels. All design proposals must be provided to VBZ in advance for approval.

Dimensions:	depending on the type of car, 16–44 m long × 37 cm base height
Moving Poster:	116,5 x 170 cm, positioning upon request

Production

The necessary aluminium panels can be picked up from VBZ. They are made available to the client but remain the property of VBZ.

Standard panels: the advertisement can be applied with adhesive material or synthetic resin. Photoluminescent dispersion is not permitted. 3-d panels and Overhanging rooftop display: it is imperative to contact VBZ in advance to discuss the approval process as well as technical feasibility. See the adjacent sketches to get an idea of the possibilities and limitations. For Overhanging rooftop display, an additional handling fee is charged. Overhanging elements must be installed on the rooftop displays in advance by the producer.

VBZ will install the rooftop displays on the vehicles and remove them again. This service is included in the price.

Booking periods / duration

Booking period:	3 months or more
Start:	anytime
Interruptions/replacements:	subject to agreement. The costs are borne by the client.



Discounts

Volume discounts:	3 or more vehicles: 5%; 6 or more vehicles: 10%
--------------------------	--

Delivery

Deadline:	Tram 2000 / smooth-runner trams no later than 10 days prior to start of campaign or by arrangement with VBZ TrafficMedia.
Location:	by arrangement with VBZ TrafficMedia

Contact

VBZ TrafficMedia:	Tel. 044 411 47 00 trafficmedia@vbz.ch
--------------------------	---

Exterior tram advertising – Tram 2000 / smooth-runner trams

Tram rooftop advertising/moving poster offers

Smooth-runner trams

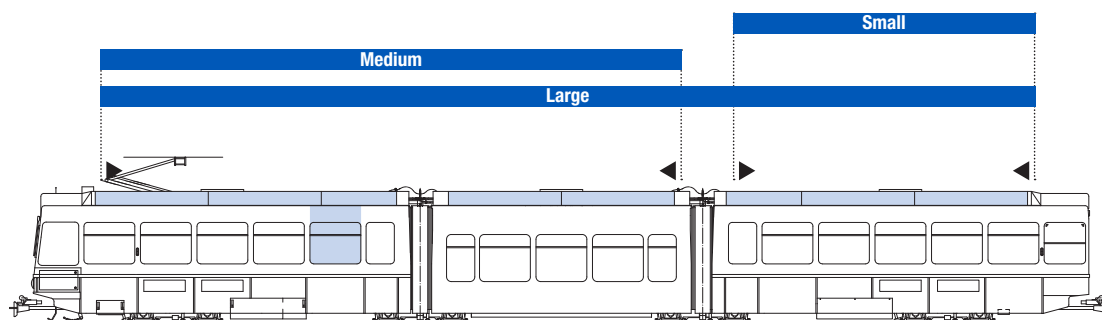

Formats

Small	800 × 37 cm /side
Medium	1400 × 37 cm /side
Large	2200 × 37 cm /side
Moving Poster	116.5 × 170 cm /side

Two-sided rooftop display

Panel type	3 months	6 months	12 months	Overhanging rooftop display
Small	2,050.–	3,450.–	5,300.–	+ 10% on top of the rental price*
Medium	4,200.–	6,800.–	10,500.–	+ 10% on top of the rental price*
Large	5,850.–	9,500.–	14,500.–	+ 10% on top of the rental price*
Medium, incl. Moving Poster	9,100.–	16,400.–	28,500.–	+ 10% on top of the rental price*
Large, incl. Moving Poster	10,750.–	19,100.–	32,500.–	+ 10% on top of the rental price*

Both vehicle sides included in the price (1 rooftop display / moving poster on each side). * For more details, see page 1.

Exterior tram advertising – Tram 2000 / smooth-runner trams

Tram rooftop advertising

Tram 2000 articulated tram cars

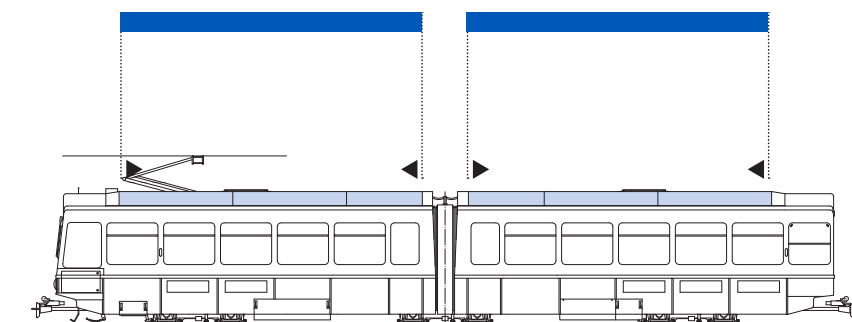

Format

1600 × 37 cm/side

Two-sided rooftop display

Panel type	3 months	6 months	12 months	Overhanging rooftop display
	4,600.–	7,400.–	11,300.–	+ 10% on top of the rental price*

Both vehicle sides included in the price (2 rooftop displays on each side). * For more details, see page 8.

Tram 2000 trailer cars

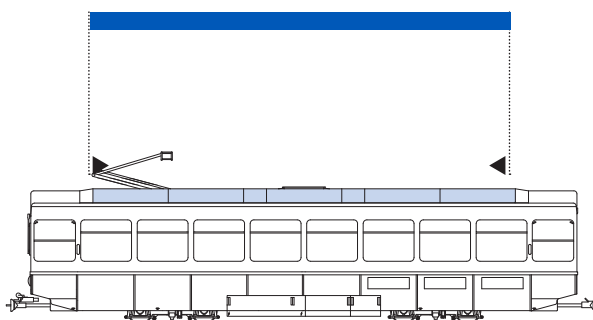

Format

1130 × 37 cm/side

Two-sided rooftop display

Panel type	3 months	6 months	12 months	Overhanging rooftop display
	2,150.–	3,350.–	5,150.–	+ 10% on top of the rental price*

Both vehicle sides included in the price. * For more details, see page 1.

Production specifications

Tram rooftop advertising/moving poster

Overhanging rooftop displays on articulated tram cars 2000 and smooth-runner trams

All figures given in millimetres.

The overhanging parts may not extend beyond the side edge of the panel.

Thickness of board: min. 8 mm forex
Logo and lettering: 800–1,500 mm

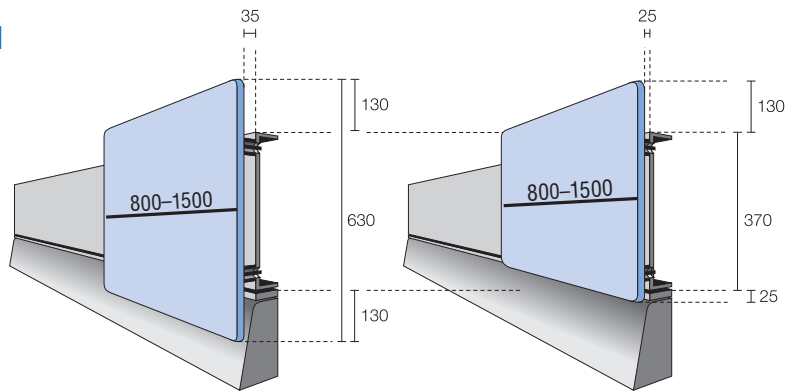

Concave angles must be rounded off.

All panel edges must be rounded off.

Radius: ca. 5 mm

