

Hanging displays in trams and buses

For cliffhangers

General information

The client shall assume the costs of design, production and transport of the hanging displays. All design proposals must be submitted to VBZ for approval in advance.

Number of units: 500 units or more guarantee a presence in every tram car / bus. It is not possible to choose specific routes.

Booking periods / duration

Booking period: at least 1 week

Start: any Monday, Tuesday and Thursday

**Interruptions/
replacements:**

subject to special agreement. The costs are borne by the client.

Refilling:

dispensers can be refilled if requested by the client. For prices see ancillary costs.

Delivery

Deadline: at least 10 days prior to start of campaign.

Delivery address: warehouse of VBZ TrafficMedia, Luggwegstrasse 67, 8048 Zurich
Please include order number and a description.

warehouse of VBZ TrafficMedia

Tel. 044 411 45 27, fax 044 411 46 83

Mon–Thu 7.30 a.m. to 4 p.m. Fri 7 a.m. to 3 p.m.

Maximum width of delivery vehicles: 2.30 m



Contact

VBZ TrafficMedia: Tel. 044 411 47 00
trafficmedia@vbz.ch

Hanging displays in trams and buses

For cliffhangers

Format/execution

Uniform poster format: 25 cm wide × 35 cm high

- Printing:** The posters can be printed on one side or both sides.
- Mounting:** the posters must have 2 pinholes, see dimensional drawing: distance of 15 cm from the centre of one hole to the centre of the other, 1 cm from the upper edge to the hole centre, hole diameter exactly 0.5 cm.

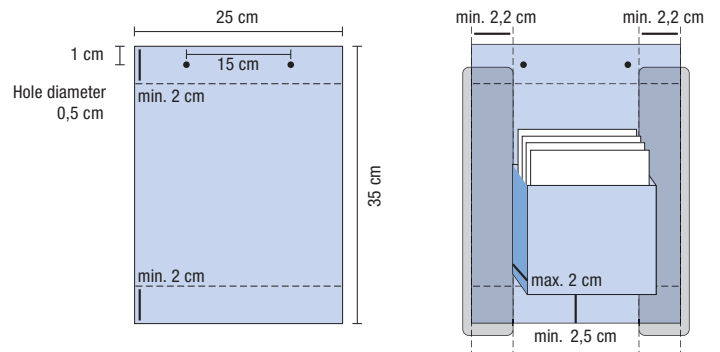

Given the way that hanging displays are attached, all important graphic elements must be located at least 2 cm from the top and bottom edges of the hanging display.

The distance of 15 cm must be measured from the centre of the holes. Hole diameter: 0.50 cm

Maximum dispenser box width: 20.6 cm

Production

- Posters:** paper weight for standard posters must be min. 400 g/m², max. 600 g/m² (thickness: 0.5 to 1 mm).
- Dispenser posters:** paper weight of 800 g/m² to prevent bending (laminated posters, 2 × 400 g/m², are also possible, provided they are flexible enough). See illustration for width and distance to edge.
- Dispenser boxes:** made of sturdy cardboard (min. 600 g/m²) and glued tuck-in flaps. The dispenser boxes need to be extensively glued to the base poster (rather than point by point) so that they do not become detached. Maximum depth: 2 cm.
- Dispenser cards:** as a rule, in A6 format, sturdy quality, delivered bound and pre-filled in the dispenser boxes.

Materials will be disposed of by VBZ after the campaign has ended if no contrary instructions are provided 10 days before the campaign starts.

- Delivery quantity for hanging displays: 10% more than the quantity ordered.
- Hole diameter: exactly 0.50 cm.
- Depth: max. 2 cm.
- The cardboard must be sturdy and flexible (0.50 to 1 mm thick).
- The dispenser boxes have to match the flyer size (at least two-thirds of the flyer height).
- Approx. 50 to 70 flyers per dispenser (guideline).
- No Plexiglas dispenser boxes.
- No folded or tucked dispenser boxes.
- No adhesive areas with double-sided tape or hot glue.
- **The hanging display must have a border of 2.20 cm on either side.**
- **Dispenser boxes must be an integrated component of the hanging display and must be affixed to the display at least 2.50 cm above the lower edge.**

Hanging displays in trams and buses

Hanging display offers

Hanging displays

Number of units	1 week	2 weeks	3 weeks	4 weeks	5 weeks	6 weeks
100	1,600.–	2,180.–	2,760.–	3,340.–	3,920.–	4,500.–
200	3,200.–	4,360.–	5,520.–	6,680.–	7,840.–	9,000.–
300	4,800.–	6,540.–	8,280.–	10,020.–	11,760.–	13,500.–
400	6,400.–	8,720.–	11,040.–	13,360.–	15,680.–	18,000.–
500	8,000.–	10,900.–	13,800.–	16,700.–	19,600.–	22,500.–
600	9,600.–	13,080.–	16,560.–	20,040.–	23,520.–	27,000.–
800	12,800.–	17,440.–	22,080.–	26,720.–	31,360.–	36,000.–

Longer campaign durations and larger quantities on request

Hanging displays with dispensers

Number of units	1 weeks	2 weeks	3 weeks	4 weeks	5 weeks	6 weeks
100	2,060.–	2,720.–	3,380.–	4,040.–	4,700.–	5,360.–
200	4,120.–	5,440.–	6,760.–	8,080.–	9,400.–	10,720.–
300	6,180.–	8,160.–	10,140.–	12,120.–	14,100.–	16,080.–
400	8,240.–	10,880.–	13,520.–	16,160.–	18,800.–	21,400.–
500	10,300.–	13,600.–	16,900.–	20,200.–	23,500.–	26,800.–
600	12,360.–	16,320.–	20,280.–	24,240.–	28,200.–	32,160.–
800	16,480.–	21,760.–	27,040.–	32,320.–	37,600.–	42,880.–

Longer campaign durations and larger quantities on request

Hanging displays in trams and buses

Hanging display offers

Ancillary cost

Description	Costs/unit
Poster replacement	4.50
Refilling of dispensers	4.50

Pool

Hanging displays (with or without dispensers) are also available for VBZ-operated bus routes in the Limmat Valley and on the Forchbahn. With the advertising pool, a campaign covering the various regions can be combined with a campaign in Zurich. VBZ offers attractive discounts when you book all of the regions.